

FURUTECH

www.furutech.com



e-TP60E Power Distributor

The e-TP60E is a sophisticated, luxuriously made single-chassis power distributor that eliminates many common problems found in audio and video components caused by massively contaminated electrical power lines.

The AC waveform becomes severely distorted by ground noise, voltage spikes and sags, high frequency power supply noise from other components in your own system, plus radiated high frequency digital noise from processors and digital interconnects. There are also distortion products at the top and bottom of the AC waveform created by switch-mode power supplies in electronic devices on the same circuit. Additionally, you're never alone; your residential AC mains supply is shared with other apartments, homes, and businesses on the same utility transformer. That's why many audio and video enthusiasts notice their systems are more enjoyable late at night or on weekends!

How can you tell you're a victim of polluted AC power? Listen and look for these symptoms: Flat, hard, and grainy high frequencies, a thick and bloated midrange, fat, uncontrolled bass, and loss of air and soundstage stability. On video displays the picture resolution is less than sharp, with "ghosting", color shift, "snow", or vertical and horizontal lines. If this looks and sounds familiar, you need Furutech!

Total Attention to Detail and Build Quality

Many A/V enthusiasts go to great lengths to carefully set up major system components, but pay little attention to the source, the AC power. Furutech knows that each and every part of the chain is as important as the next, so maximum attention is lavished on *all* aspects of AC power transfer.

The beautifully crafted special grade aluminum chassis effectively shields against another common problem, RFI (Radio Frequency Interference) and a layer of Formula GC-303 blocks

EMI (Electro Magnetic Interference). Internal wiring is Furutech μ -14 conductor shielded with Special Polyethylene, guaranteeing low electrical resistance.

Furutech Hyper Quality High Performance 24k Gold-plated SCHUKO Sockets are “star-wired” to the High Performance 24k Gold -plated IEC inlet of the e-TP60E sets of conductors for each of the six SCHUKO Sockets. They feature 24k Gold-plated Eutectic brass, non-magnetic conductors for stable, long lasting, optimized power transfer.

Formula GC-303

GC-303 is a special material Furutech bonds to the interior bottom-plate of the chassis that absorbs EMI (Electromagnetic Interference) generated by the internal fittings of the unit. The e-TP60E uses no filtering besides Formula GC-303 so AC resistance is kept to a minimum (see below), allowing a more resolving, powerful, dynamic, and colorful performance from your components.

GC-303 Absorbs Internally Generated EMI

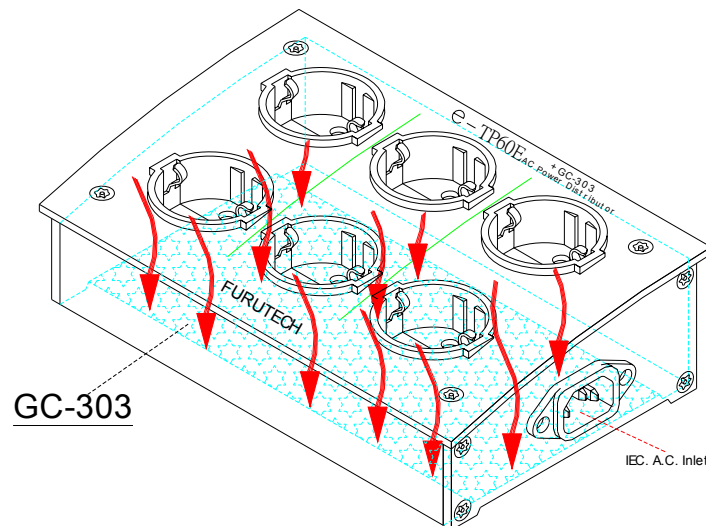

Furutech's Two-Stage Cryogenic and Demagnetizing *Alpha Process*

Using cutting-edge technology and materials, Furutech developed a low-temperature two-stage process that significantly improves every facet of audio and video performance. The treatment begins during the manufacturing process with a deep, conditioning cryogenic freeze of all metal parts. Using high-end refrigerants -- liquid N₂ or He -- Furutech achieves temperatures of between -196 to -250°C. The treated parts actually change their molecular structure at these extremes of temperature relieving internal stress. The molecules bond together more tightly and the overall structure becomes more stable. This improves electrical conductivity and so power and signal transfer.

Step two in the *Alpha Process* exposes these same parts to the patented Ring Demagnetization treatment. Ordinary high power magnets used for this purpose often *increase* magnetic effects; they leave some areas more magnetized than others. This patented process uses controlled attenuation to completely eliminate magnetization for immediately more vivid and colorful

improvements. Ring Demagnetization further enhances conductivity of all treated materials. The patent holder for this treatment is Sekiguchi Machine Sale Co., Ltd. in Japan; Furutech are licensed users of the technology.

ALL metallic parts used in Furutech products go through the Alpha Process treatment to keep all connectors, conductors, and metal parts in a perfect stress-free, stable and highly conductive state.

The Final Result

The 2-Step Alpha Cryogenic and Demagnetizing Process works in tandem with other designed-in features to create the most optimized AC power transfer possible. Furutech’s scientific outlook, total awareness and devotion to detail results in a greater sense of power, dynamics, and resolution, with cleaner, blacker backgrounds and a larger, more stable soundstage, vivid tonal colors and deeper extension at both ends of the frequency range. The e-TP60E will allow the delicacy, refinement and nuance of a performance through, along with micro- and macro-dynamics that will leave you breathlessly engaged. Displays of all types will exhibit greater, sharper resolution with less ghosting, color shift, “snow”, or vertical and horizontal lines.

SPECIFICATION

TYPE SPECIFICATION		e-TP60E	TYPE SPECIFICATION		e-TP60E
	VOLTAGE	AC 250V 50/60Hz		MOVEMENT TEMP.	-10℃~40℃
	CURRENT	10 A		PRESERVATIVE TEMP.	-20℃~50℃
	LOADING WATT.	2500 W		BODY MATERIAL	Aluminum Alloy (Black Painted)
	GROUNDING OUTLET	6 Outlets		OUTWARD SIZE	200(W)X130(D)X60(H) mm
	FILTER TYPE	GC-303 Absorbs EMI		WEIGHT	0.94Kgs

CIRCUIT PATH

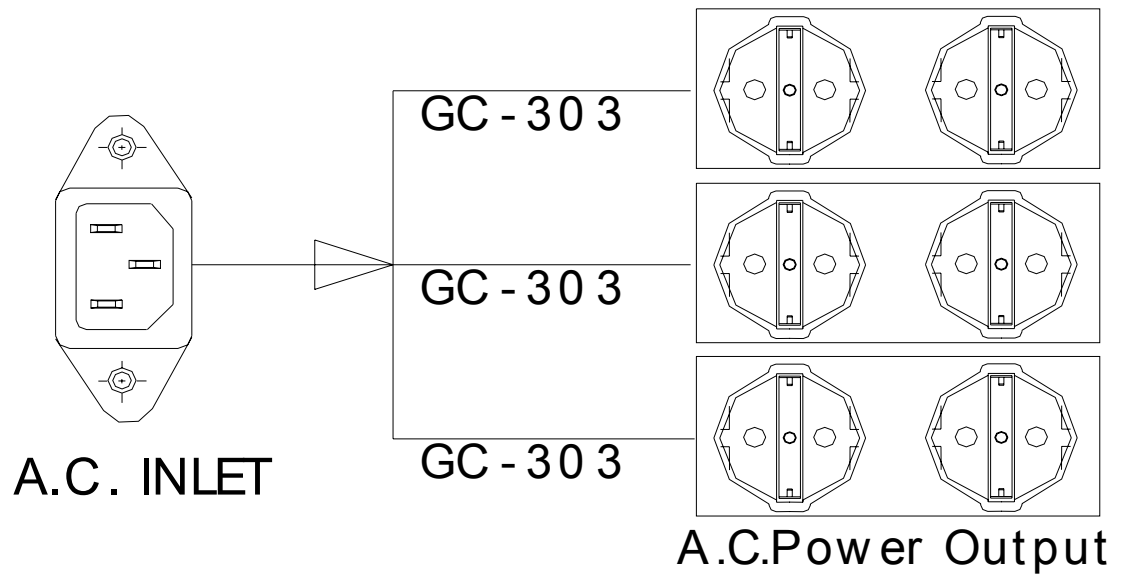

***All Metal Parts Treated With
FURUTECH Alpha Cryogenic and Demagnetizing Treatment***

FURUTECH reserves the right to change product specifications without prior notice.

FURUTECH CO., LTD.

www.furutech.com

service@Furutech.com

Make A More Powerful Connection with Furutech!